

Standard Thermometer

Model 670

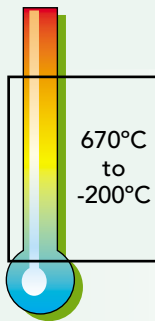

This is the first new thermometer, after the introduction of ITS-90, to be specifically designed to give optimum performance up to the aluminium point. Its construction permits the four internal platinum lead wires to expand and contract in the same manner as those of silver-point thermometers. The all-quartz construction of the support-members gives the most stable performance with minimal drift, and a unique platinum radiation shield prevents heat radiating up the inside of the sheath. The temperature range and design of this new unit means that we offer 25.5Ω (R_0). The construction, including the coiled sensing element, heat-shunt baffles and light scattering barriers, creates a thermometer of unsurpassed stability. Because the 670 goes beyond the temperature range of oxide growth to the level at which the oxide dissociates, the 670 is filled conventionally with argon containing 10% oxygen.

A 2-metre length of low thermal emf, high temperature, screened cable is connected in the handle, via a strain-relieving transition, to the all pure-platinum construction of the thermometer. Gold-plated U-shaped terminals complete the cable construction, and the 670 is delivered in an elegant soft lined carry-case of our own design.

A 670 is delivered only after a stabilising process which is complete when the reproducibility of R_{TPW} is within 0.0005°C after excursions to the extremes of its temperature range. Values of R_{TPW} and W_{GA} are routinely provided with the 670.

The 670 can be supplied with R_{TPW} and W_{GA} only or with full UKAS calibration. "With calibration" means that you will get an Internationally accepted Fixed Point calibration.

For best accuracy, recommended maximum measuring currents for the 670 is 1mA although up to 10 times this current should not permanently damage the standard.

A comprehensive handbook and tutorial will help you get the very best performance and stability from your 670.

The thermometer has a standard length of 650mm.

Model No	670/25.5
Temperature Range	-200°C to 670°C
Resistance Value ($^\circ\text{C}$)	25.5Ω R_0
Resistance Ratio	$W_{GA} > 1.11807$ as required by ITS-90
Sensitivity	$0.1\Omega/^\circ\text{C}$
Long term drift	from $0.001^\circ\text{C}/\text{year}$
Calibration (UKAS)	Water T.P., Tin F.P., Zinc F.P., Aluminium F.P. with print-out of temperature at W-intervals of 0.01. Please see Databook 5

See T.T.I. 2 and T.T.I. 3 for suitable readout instrument.

How to order

Model 670/25.5

State "with UKAS Calibration" or "without UKAS Calibration".

Refer to Databook 5 for temperature ranges.

In default of information you will be supplied with a 670/25.5 without calibration

Standard Platinum Resistance Thermometer



Standard Thermometer

Model 670

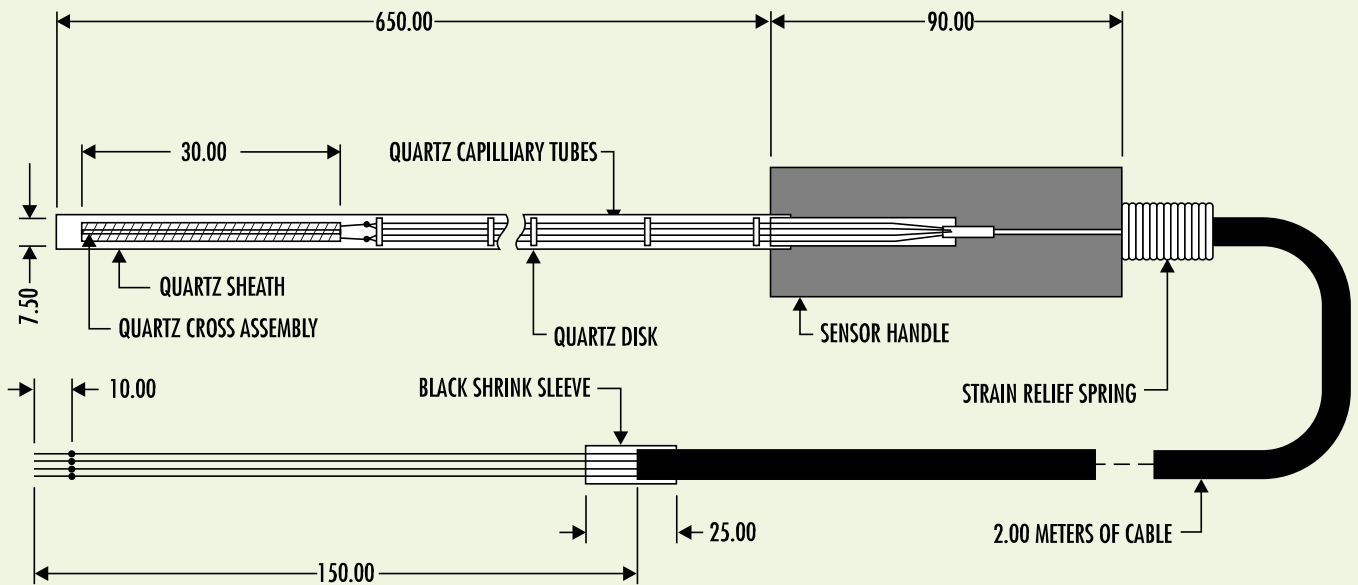

N.B. Please note that if the sheath becomes broken it is not possible to re-seal it; however, if it is possible to remove the broken fragments, another sheath can be supplied to fit over the internal parts, provided that these have not been damaged or contaminated. Use should then be restricted to 0°C and above

SPRT's

Having selected the finest cells and apparatus these must be matched by the finest SPRT's. With nearly thirty years experience of manufacturing platinum resistance thermometers for science and industry it is not surprising that we have developed the finest standard thermometers.

Two models offer outstanding performance and are the preferred standards at Isotech's Primary Laboratory. These are the 670/25 and the 96178/0.25 thermometers. Extensive evaluations have been written about the thermometers which are available free of charge.

The benefits to your laboratory are increased stability, longer life with better performance and less contamination.