

915 Parallel Tube

Liquid Bath

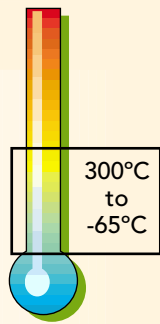

The 915 is a stirred liquid bath, designed, refined and updated to meet CE standards, the 915 is, no question, the finest stirred liquid parallel tube bath produced.

Typical uncertainties of measurement are less than $\pm 0.0005^\circ\text{C}$ over the complete temperature range -65°C to $+300^\circ\text{C}$.

915 PARALLEL TUBE LIQUID BATH

A full evaluation report is available upon request.

The Isotech Parallel Tube Liquid Bath is a development of the previous 815 model and has many features which enhance its performance and enable ease of operation. It is suitable for the calibration of Liquid in Glass thermometers, Industrial Platinum Resistance thermometers, Standard Platinum Resistance Thermometers, Thermocouples and Industrial Temperature sensors. It can also be used with fixed point cells.

The temperature range of the standard 915 liquid calibration bath (915H) is 40°C to 300°C . When the 915 is used in conjunction with our external chiller this temperature range can be extended from -65°C to 300°C , refer to model types available below.

The 915 has a wide temperature range using silicon oils and other suitable liquids. All components in contact with the liquid are of stainless steel and are insulated with materials which are completely safe in use. The 915 used in conjunction with a chiller, utilises the latest ozone friendly gases.

Liquids are circulated by a propeller which mixes and forces the liquid through a specially designed orifice in the rear of the two parallel tubes. A variable speed motor optimises the flow as the viscosity of the liquid changes. Below the orifice plate liquid is circulated over a mineral insulated heater and temperature sensors which control the temperature of the bath. The liquid flows up the calibration tube and weirs over the tube into a collection tray where it returns to the rear tube for recirculation. An angled side entry tube enables a refrigeration cooling probe to be inserted in the rear of the two parallel tubes.

The temperature controller has resolution from 0.01°C to 0.1°C which auto scales to suit the four digit display (all digits can be read with the Cal NotePad Software). The 915 is fitted with serial communications for interfacing to a PC as standard.

With the high cost of some silicon oils the 915's seven litre capacity makes it relatively inexpensive to fill compared to many other baths.

The changing of liquid is easily enabled by using the fitted drain. The design also allows for the expansion of liquids when being raised to a particular calibration temperature.

Model Types	915H Standard Unit, 915MWE supplied with chiller 915/10, 915 LW supplied with chiller 915/11
Temp Range	915H 5°C above ambient to 300°C 915MWE -30°C to 40°C 915LW -65°C to 40°C
Absolute	Using Fixed Point Cells $\pm 0.0005^\circ\text{C}$ Mercury Triple Point, Water Triple Point, Gallium Melt Point, Indium Freeze Point, Tin Freeze Point
Vertical Profile	At extreme temperatures $\pm 0.003^\circ\text{C}$ At close to ambient $\pm 0.001^\circ\text{C}$
Temperature Stability by Comparison	Direct in Liquid $\pm 0.001^\circ\text{C}$ In Equalising Block $\pm 0.0005^\circ\text{C}$
Communication	Supplied as standard with serial interface, PC adaptor cable and Cal NotePad. Refer to page 46
Liquid Capacity	Approximately 7 litres
Working Volume	100mm diameter by 400mm depth
Overall dimensions	Height 1020mm Width 580mm Depth 640mm
Weight	45kg approximately
Power	1kW (excluding Chiller) 108-130 or 208-240V, 50/60Hz
Installation	Via single phase supply
Safety	Variable set-point over-temperature trip. Automatic over-fill protection tube
How to Order	
	915H, 915MWE or 915LW Parallel Tube Liquid Bath
	Please specify voltage and frequency required



915 Parallel Tube

Liquid Bath

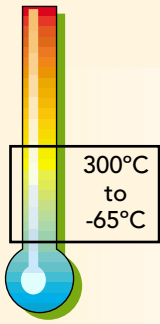

For customers who require lower temperatures the range of the 915 bath can be extended by the addition of a chiller unit, see photograph below and the chart of model types available.

The chiller unit's probe (203mm long by 32mm diameter) is inserted into the angled side entry tube, accessible from the top of the cabinet, leaving the calibration volume of the bath unchanged.

The following chiller options are available, we recommend and supply the following:

Order Code	Description	Temperature Range min/max	
915/10	Single Stage Wide Range Chiller	-30°C	40°C
915/11	Dual Stage Wide Range Chiller	-65°C	40°C

These chillers have both good reliability and wide operating ranges. They contain safe, ozone friendly gases.

The temperatures stated above assume an ambient within the range of 20°C to 25°C.

Single Stage and Dual Stage Chiller Cool Down Graph

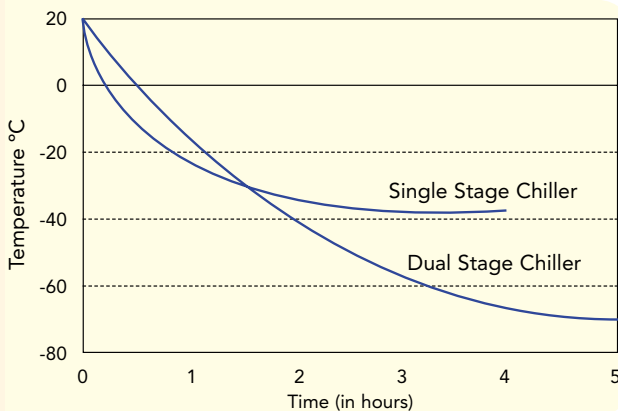

Controller Note:

The controller includes features custom designed for Isotech by a world-leader in temperature control technology. Power feedback is used to stabilise against supply voltage changes, leading to greater stability. A digital filter circuit ensures high integrity of measurement correcting for drift, rejecting 50/60HZ pick-up and filtering out other sources of input noise. The four-digit display autoscales from 0.01° to 0.1°.

Accessories



IMPORTANT

Chiller probes must be removed from the Calibration Bath when used above their maximum temperature as stated above.

HEALTH AND SAFETY NOTICE

Rooms in which high temperature liquids are used should be ventilated or have extraction facilities. Although the overall temperature range of the bath is -65°C to 300°C the practical temperature range which can be achieved is dictated by the liquid being used and the ambient temperature.

915 Parallel Tube

Liquid Bath

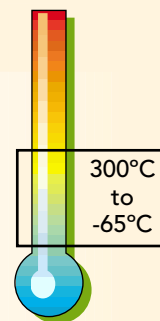

ACCESSORIES

The following options are available:

- 915/01a** Available for the Isotech parallel tube bath is a variable depth aluminium equalising block containing four drilled pockets 8mm diameter by 120mm deep in which temperature sensors can be placed and is suitable for use with silicon oils.
- The equalising block is suspended centrally within the calibration tube and is easily removed.
- 915/01b** As an alternative to the above a copper equalising block, dimensionally the same as 915/01a, may be supplied. This block is more suitable for use in water and other liquids.
- 915/D** Increased depth Calibration Tube Assembly. Working volume is 100mm diameter by 530mm deep. This variant allows for the calibration of very long thermometers, typically the calibration of long liquid in glass thermometers. See also 915/02.
- 915/02** This assembly will hold up to 12 liquid in glass thermometers (maximum diameter 12.7mm) radially and a centre mounted standard sensor. The assembly may be rotated allowing systematic calibration. The assembly is designed for partial or full immersion of thermometers.
- 915/03** Monocular and Support. Useful for viewing and magnifying the liquid column within the thermometer being calibrated. This ancillary piece of equipment is used in conjunction with 915/02 Liquid in Glass Thermometer Support Kit.
- 915/05** Calibration Tube Cover. The cover consists of a square enclosure containing baffles and fits over the calibration tube area insulating the circulating liquid from ambient air. Access for temperature probes remains at the top of the enclosure. An equalising block may also be supported from this assembly. Maximum operating temperature 180°C.
- 915/07** Medium Temperature Silicon Oil. Temperature Range 40°C to 180°C. Supplied in 9 litre containers. Flash Point 300°C.
- 915/08** High Temperature Silicon Oil. Temperature Range 150°C to 250°C. Supplied in 9 litre containers. Flash Point 315°C.
- 915/09** Very High Temperature Silicon Oil. Temperature Range 40°C to 288°C. Supplied in 2 x 5 litre containers. Flash Point 288°C.
- 915/E** Hybrid Analog / Digital Controller available. Includes RS232 as standard, 0.01°C resolution over the full temperature range. Provides enhanced short term temperature stability.

NOTE: Read all safety information concerning liquids which you intend to use in the bath and use only approved liquids.

Fixed Point Calibration ITS-90 Cell Basket Assemblies (Excluding Cells)

915-05-43	Small Mercury Cell Kit
915-05-44	Large Mercury Cell Kit
915-05-41	Small Water Triple Point Cell Kit
915-05-40	Large Water Triple Point Cell Kit
915-05-39	Small Gallium Cell Kit
915-05-38	Large Gallium Cell Kit
915-05-42	Slim Cell Kit

For information on Fixed Point Cells please refer to Databook One and pages 28 - 31 of this Databook.

915 Parallel Tube

Liquid Bath Schematic

915 PARALLEL TUBE LIQUID BATH
DIAGRAMMATIC

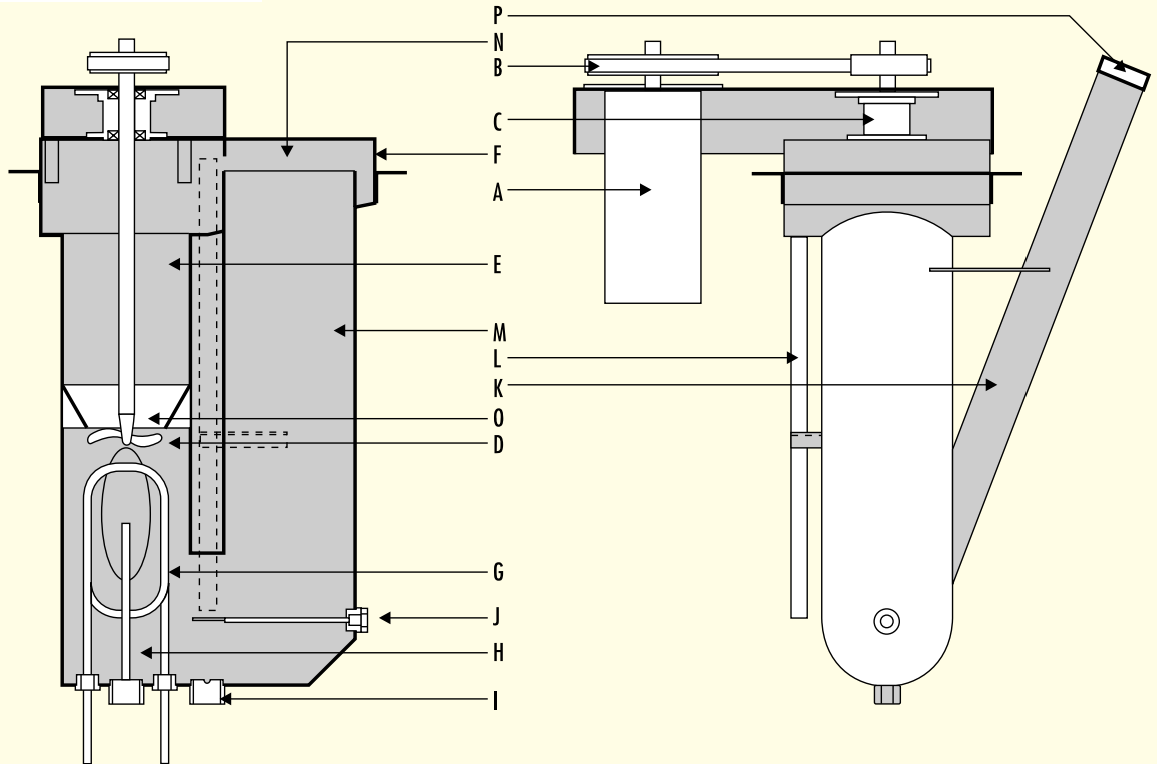

915 CALIBRATION ASSEMBLY DEVELOPMENT, INFORMATION REFERENCE

- A** Motor (Low Voltage)
Variable Speed Controlled.
- B** Drive Belt
- C** Bearing Housing
- D** Propeller
- E** Circular Mixing, Cooling and Heating Chamber. Circular Profile to prevent uncirculated pockets of liquid
- F** Large Volume Liquid Tray, which caters for the expansion of the liquid when heated
- G** Mineral Insulated Heater
- H** Over-Temperature Sensor
- I** Large Capacity Drain
- J** Control Sensor
- K** Cooling Probe Entry Tube, allowing total probe immersion. Intended for use with an external chiller unit

- L** Overflow Pipe
- M** Calibration Area
- N** Liquid Weir. An extension is available to enable the calibration of Mercury and Glass Thermometers

- O** Orifice Plate, increases the differential height of the liquid between front and rear tubes
- P** Screw Cap. Fitted when cooling Probe is removed

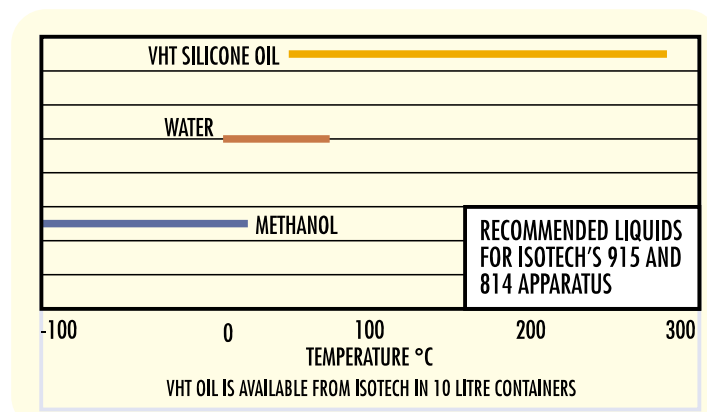

Note: Methanol has serious health & safety problems. Consult safety documentation before use.